

Sean Brown

Selected Works



Sean Brown is a multidisciplinary creative and cultural archivist. His approach to reimagining the future of product development and design is informed by a broad referential vocabulary, underpinned by a desire to show equal reverence to non-traditional and institutionally acknowledged artifacts of importance.

An early exploration of fashion illustration proved a gateway to honing his appreciation of silhouette and form, leading to a curatorial perspective that became the foundation of his 2010 conceptual luxury vintage retail space, The Art Of Reuse. An opportunity to bring this pop-up retail experience to several notable North American markets intensified Sean's love of travel which would become a recurring theme intrinsic to his practice ideologically and in the tangible form of future brand collaborations.

2013 saw Brown launch his elevated take on sportswear with his NEEDS&WANTS label. The line was accompanied by a biannual publication of the same name, providing lifestyle context embodying the spirit in which the clothing was conceived. His discerning eye used the pages to frame the sensibilities of his NEEDS&WANTS consumer in the areas of design, travel, architecture, and flora to name a few. An immersive and multi-sensory consumer activation in a repurposed 8ft x 20ft shipping container was well received as a fully actualized embodiment of the brand.

In 2015 Brown's multi-hyphenate nous led him to an inevitable role at the intersection of music and imagery, becoming musician Daniel Caesar's creative director. In partnership with Keavan Yazdani. The brief was a utilitarian one with Sean's duties touching on visual media, styling, and art direction. Under Brown's creative stewardship, Caesar's career simultaneously reached new heights culminating in a 2018 Grammy Award while Sean gained acknowledgment in the form of an Audience Award at the 2018 Prism Prize Award show for his contributions to Caesar's "Freudian, A Visual". Brown also received a Juno Awards nomination for Album Artwork Of The Year.

In July of 2018, Sean Brown announced his arrival in the world of fine art at the Peter MacKendrick Gallery in Toronto with his inaugural solo show entitled "CURVES". An interactive showing including a collection of photo essays and objects, "CURVES" sought to reverse engineer Brown's creative process providing an open-source glimpse into his work across disciplines by revealing source material presented in a way to comprise the show itself. The second and third installations of CURVES were held at the Letter Bet in Montreal and at the Royal Ontario Museum in Toronto, respectively.

During the pandemic of 2020, Brown's insatiable desire to create saw an explosion in popularity for his first foray into the home goods space. Retaining the name "CURVES", the brand's mission is simple. Democratization of access to tasteful interior design in a typically elitist and exclusionary space. The objects

are an amalgam of Brown's viewpoints articulated in expressions of color study, form, and unconventional materials. The wildly popular rugs which replicate iconic CD albums have developed a ubiquitous presence on social media while CURVES is now carried by select retailers including online fashion giant SSENSE and venerable London department store, Selfridges.

What's next for Sean brown? With 2022 seeing an ever-increasing number of digital and print cover stories and media coverage including a New York Times feature, his career trajectory is in steep ascendancy. Brands in the luxury sphere including RIMOWA and Jean Paul Gaultier can now be counted as collaborators. Future projects include a tentatively titled print publication aimed to disrupt the documentation of people's homes. His architectural design endeavor HYPATIA communicates his vision for dwelling with a deeply considered approach to design, fostering a harmonious symbiosis between human and environment with an emphasis on wellness of the mind and spirit.

"No one is going to give you license to use your imagination or prevent you from copying what already exists; that's (y)our creative responsibility. To find and add truth to what already exists, you develop alternative approaches to what has been done, or discover what has yet to be done."—Sean Brown.

● Product Design

Graphic Design

Photography

Art Direction

Directing

Spatial Design

Galleries & Installations



Fine Art Rug
Curves by Sean Brown

● Product Design

Curves by Sean Brown
White Extended Archway Chair

Curves by Sean Brown
Handmade CD Rug

RIMOWA
Trunk Lamp (Art Basel)



● Product Design

Plasiq

The Multiflora Cube™, 2019.

Dusted 3M vinyl on acrylic.

Made in three different sizes; 3x3x3, 2x2x2, 1x1x1.



● Product Design

NEEDS&WANTS

Graphic Design

Photography

Art Direction

Directing

Spatial Design

Galleries & Installations



● Product Design

NEEDS&WANTS



● Product Design

NEEDS&WANTS



We Find Love

Даниел Сийзър

Product Design

● Graphic Design

Photography

Art Direction

Directing

Spatial Design

Galleries & Installations

We Find Love, 2017.
Daniel Caesar
(Photography, design)

Cover Art

● Graphic Design

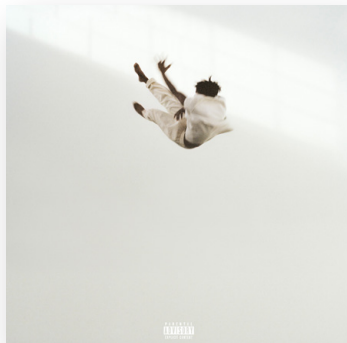

Pilgrim's Paradise, 2015.
Daniel Caesar
(Creative direction, styling, graphic design)

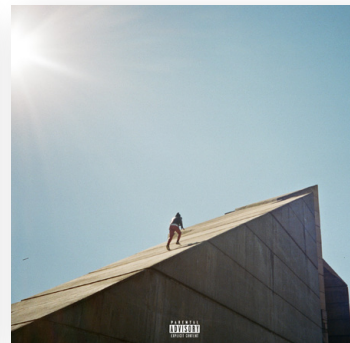

Freudian, 2017.
Daniel Caesar
(Creative direction, photography,
album artwork & packaging design)



Case Study 01, 2019.
Daniel Caesar
(Creative direction, photography,
album artwork & packaging design)

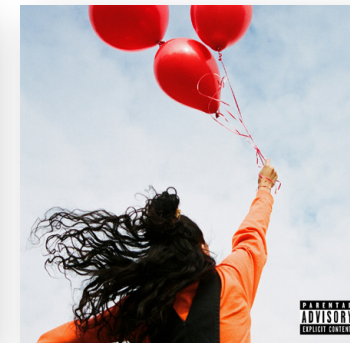

Figures (remix), 2018.
Jessie Reyez & Daniel Caesar
(Photography, design)



K. Roosevelt, 2018.
K. Roosevelt
(Art direction, photography, design)



Adrenaline (single), 2018.
K. Roosevelt
(Art direction, photography, design)

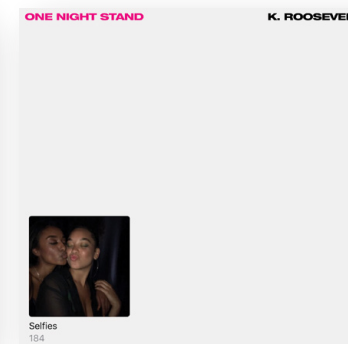

One Night Stand (single), 2018.
K. Roosevelt
(Art direction, photography, design)



Peace of Mind (Album), 2020.
Jay Whiss
(Art direction, photography, design)

Cover Art

● Graphic Design



Not What I Thought (single), 2019.
Amaal
(Art direction, photography, design)



Coming and Going (single), 2019.
Amaal
(Art direction, photography, design)



No Good / Scary Lover (A/B side), 2019.
Jesse Gold
(Art direction, photography, design)



We'll Be Fine, 2019.
Jesse Gold
(Art direction, photography, design)



Five Miles High, 2020.
New West
(Photography, design)



Balenciaga, 2020.
New West
(Art direction, photography, design)



Hit Different, 2020.
SZA
(Art Direction, design)



Fair, 2022.
Normani
(Art direction, design)

Physical Albums CD / Vinyl



Graphic Design

Case Study 01 (US) - Vinyl
Daniel Caesar
(Photography, design)



Case Study 01 (US) - CD
Daniel Caesar
(Photography, design)

Pilgrim's Paradise - CD Booklet
Daniel Caesar
(Art direction, design)



A CAPPELLA

When I look upon your face, hold it in a sweet embrace / When I enter in that place, I'll sing it's praise / If we fill our voices high, as it flows pass us by / And our voices tell your tale, I'll enlighten up my friends

(A. Simmonds, J. Evans) Produced by Jordan Evans. Recorded by Jordan Evans at East West Digital Studios, CA. Written by Daniel Caesar, Christopher Daniel Caesar & Jordan Evans. All vocals by Daniel Caesar. Mixed by Jordan Evans at East West Digital Studios, CA.

Enlighten up my friends.

Product Design

Graphic Design

● Photography

Art Direction

Directing

Spatial Design

Galleries & Installations



Daz Merchant, 2022.
Photography

Film Archive



Hoda (2018).



Sitges, Spain (2018).



Kerid Crater, Iceland (2019).



Daniel Caesar (2019).



Khleo II (2021).



Cairo, Egypt (2018).

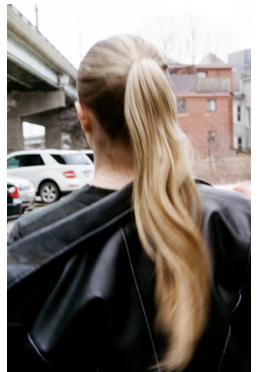

Charlotte Day Wilson (2018).

Film Archive



Ascension Ad Campaign (2020).



Amaal Nuux (2019).



Kaj (2020).



Khleo (2021).



Isabel (2019).



Ilka (2018).

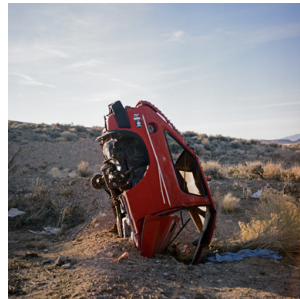

Goldfield, Nevada (2017).



Faiyum, Egypt (2018).

In No Particular Order
Vol 1 & 2

-
- Photography



Product Design

Graphic Design

Photography

● Art Direction

Directing

Special Design

Galleries & Installations



Deleon Tequila-Holiday Gift Set
(Design, direction)

The Art of Reuse-Ad
(Art direction)

Curves Catalog (2021)
Curves Catalog (2022)

- Art Direction

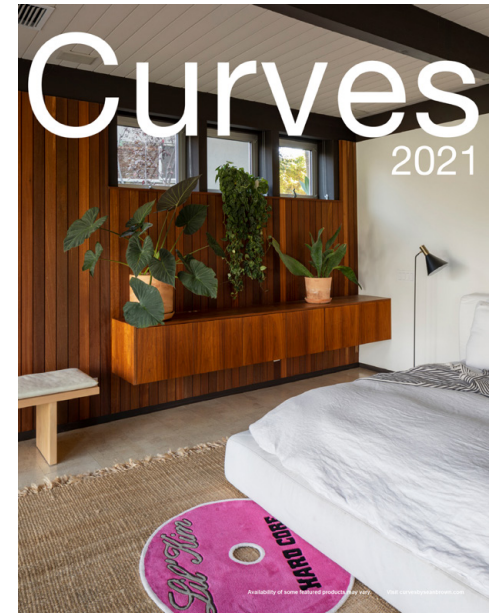

Product Design

Graphic Design

Photography

Art Direction

● Directing

Spatial Design

Galleries & Installations

Daniel Caesar—Freudian, a Visual (2017)

Directed by Keavan Yazdani & Sean Brown
*2018 Prism Prize Audience Award Winner
[Watch here](#)

Daniel Caesar & H.E.R.—Best Part, a Visual (2018)

Directed by Keavan Yazdani & Sean Brown
[Watch here](#)

Amaal—Not What I Thought (2019)

Directed by Sean Brown
[Watch here](#)

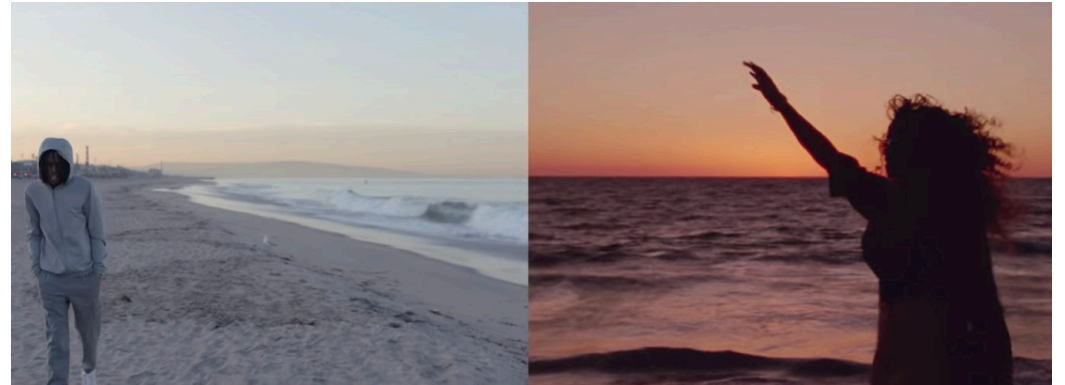

Product Design

New West—Call Me When You Hear This Song (2019)

Directed by Sean Brown
[Watch here](#)

Graphic Design

CIROC—White Grape (2020)

Directed by Sean Brown
[Watch here](#)

Photography

Art Direction

● Directing

Spatial Design

Galleries & Installations

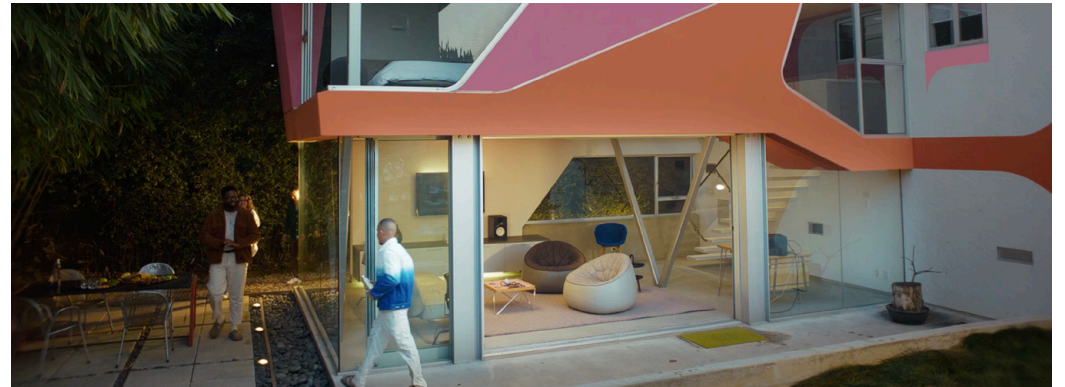

Product Design

Graphic Design

Photography

Art Direction

Directing

● Spatial Design

Galleries & Installations



HYPATIA Spacemaking

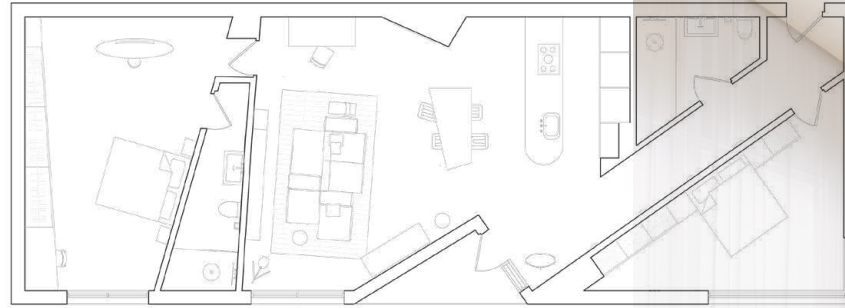

Northface Renewed Container (Pitch)



-
- Spatial Design

Northface Renewed Container
Designed in collaboration with Eric Lachance

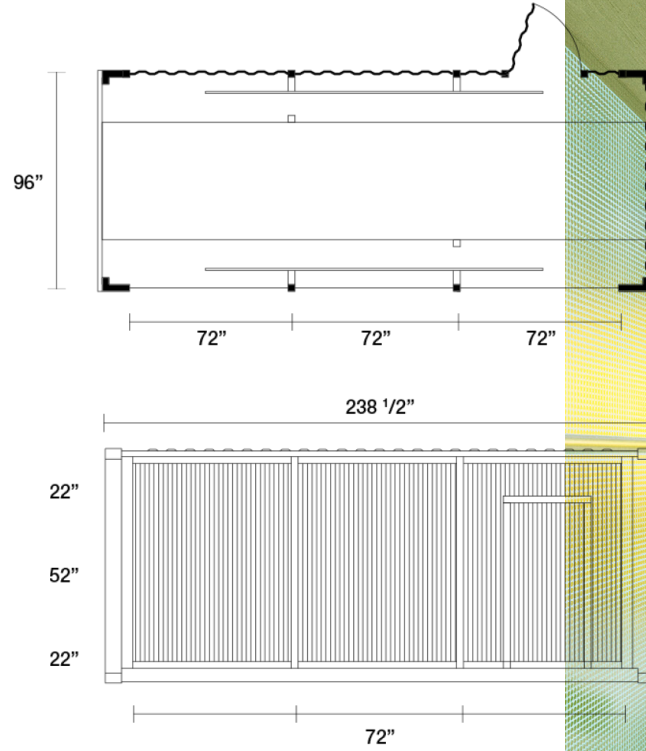
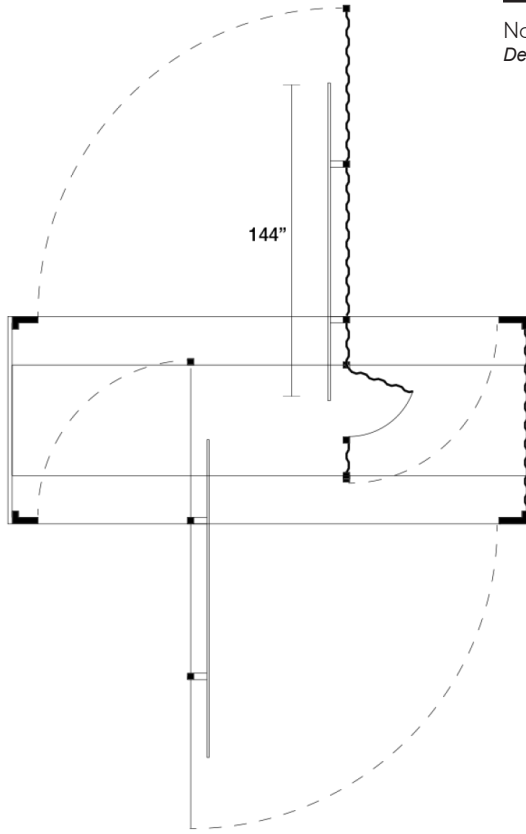

● Spatial Design



Aurora Phase Garden (NXNE, 2018)

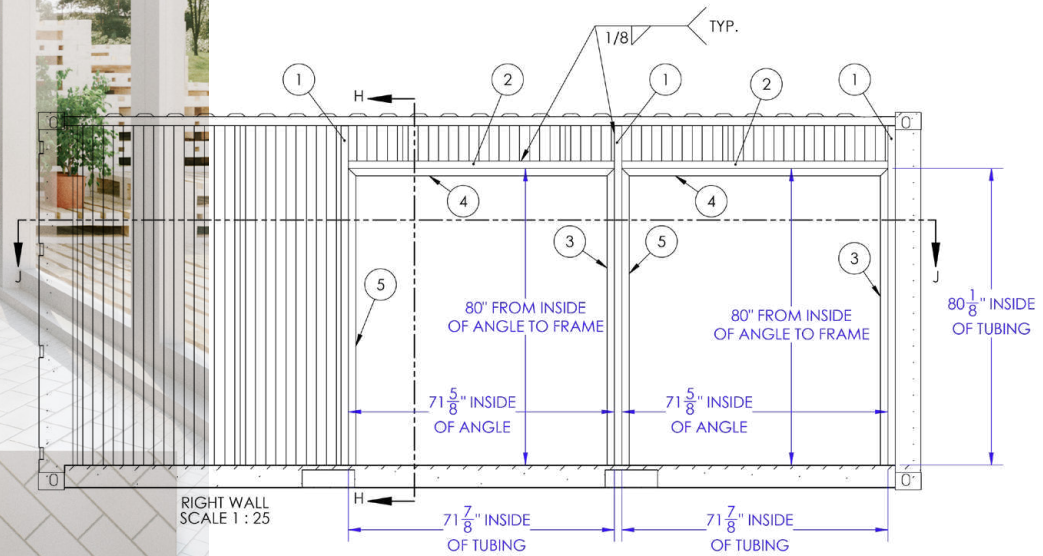

NEEDS&WANTS Shipping Container (2016)





Product Design

Graphic Design

Photography

Art Direction

Directing

Spatial Design

● Galleries & Installations

Curves at The ROM
Galleries & Installations

Curves at Peter Mckendrick Gallery (2018)
Curves at The Letter Bet (2018)
Curves at The POM (2018)



● Galleries & Installation



Curves at Peter Mckendrick Gallery (2018)
'In No Particular Order' Installation (2019)



● Galleries & Installation



A person is shown from the back, wearing a dark-colored jacket with light-colored stitching. Their arms are raised high, and the jacket is billowing out, suggesting movement or a dramatic pose. The background is a plain, light color.

This booklet and any attachments may contain privileged information.
Any unauthorized use, extraction or disclosure is prohibited.
Copyright © 2022 All rights reserved. byseanbrown.com